

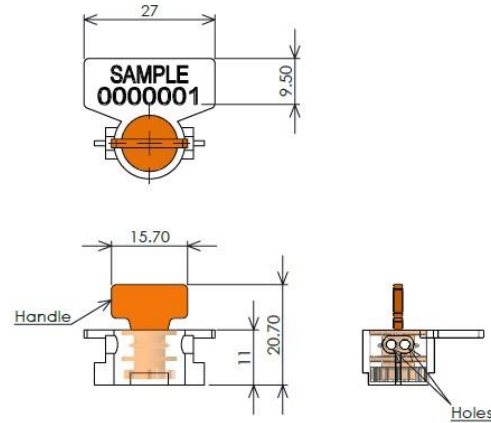

TWISTER S SEAL Data Sheet

Acme Reg No: 3109013

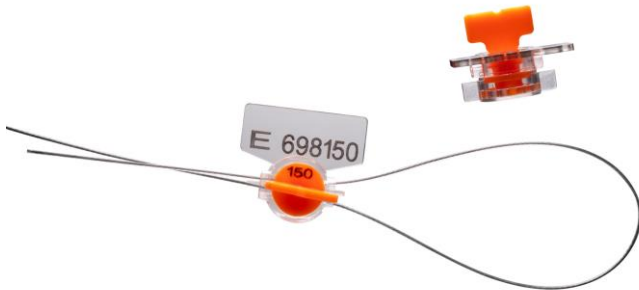

The Acme **Twister S Seal** is a two part Polycarbonate wire seal that offers an alternative to lead and plastic wire seals but has the added advantage that it can be applied without the use of a sealing tool. The seal is applied by threading the wire through the appliance holes then passing the two ends of the wire through the holes of the transparent casing and integral colour coded twister insert. The colour insert is then turned clockwise and the wire is wrapped around the inner cores until the handle is broken off, indicating that the seal is lock and cannot be removed. Used with spiral stainless steel with nylon coated wire, this seal, with its transparent body and coloured insert offers a visual control of integrity and colour coding. The Twister S Seal can only be removed with wire cutters.

Technical Data

Recommended Applications

Electric, Gas and Water meters, Drums, Totes, Petrol Pumps, Taxi meters, Weighing scales.

Material

Body - Polycarbonate
Insert - Polycarbonate

Available Wire

Wire - 0.7mm diameter (Standard Length 30cm)
Material - Stainless steel with Nylon coated
Reels or other cut lengths may be available on request

Tag Marking Dimensions

27mm x 9.5mm

Marking

Laser marking
Consecutively numbered as standard
Optional Customer name/logo
Optional Laser Barcoding

Insert Colours

Red, blue, green, yellow, orange, black, white.
Other colours may be available on request.

Packaging

Standard Packaging : 5,000 seals/carton (50 polybags)
Carton Dimensions : 49cm x 40cm x 25cm
Carton weight : 13.1kg/carton