

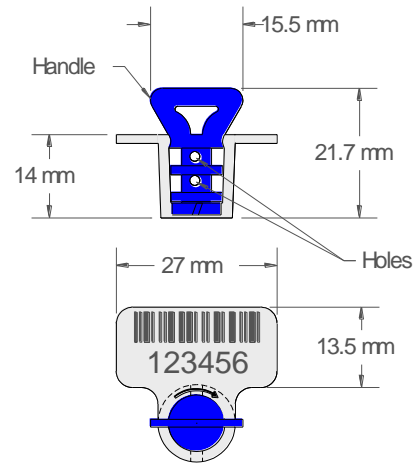

## TWISTER SEAL Data Sheet

Acme Reg No: 1606011

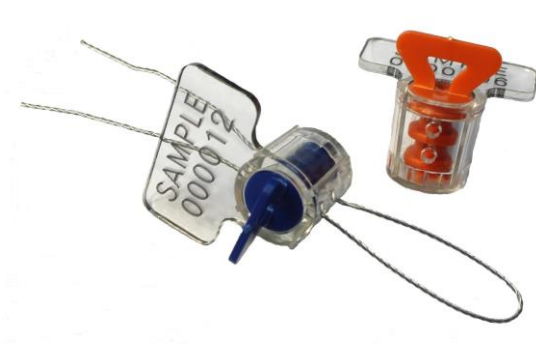

The Acme **Twister Seal** is a two part Polycarbonate wire seal that offers an alternative to lead and plastic wire seals but has the added advantage that it can be applied without the use of a sealing tool. The seal is applied by threading the wire through the two holes of the transparent and coloured pieces and by turning the insert clockwise the wire is twisted around the inner cores until secure at which time the handle is broken off. Used with spiral soft galvanised, stainless or nylon coated wire, this seal, with its transparent body and coloured insert offers a visual control of integrity and colour coding.

### Technical Data

#### Recommended Applications

Electric, Gas and Water meters, Drums, Totes, Petrol Pumps, Taxi meters, Weighing scales.

#### Material

Body - Polycarbonate  
Insert - Polycarbonate

#### Available Wire

Wire - 0.7mm diameter (Standard Length 30cm)  
Material - Galvenised, Stainless or Nylon coated  
Reels or other cut lengths may be available on request

#### Tag Marking Dimensions

27mm x 13.5mm

#### Marking

Laser marking  
Consecutively numbered as standard  
Optional Customer name/logo  
Optional Laser Barcoding

#### Insert Colours

Red, blue, green, yellow, orange, black, white.  
Other colours may be available on request.

#### Packaging

Standard Packaging : 5,000 seals/carton (50 polybags)  
Carton Dimensions : 49cm x 40cm x 25cm  
Carton weight : 13.1kg/carton