

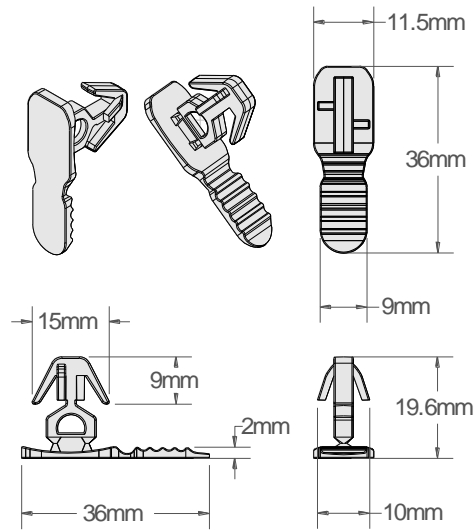

AC05 SEAL Data Sheet

Acme Reg No: 30062020



The Acme **AC05 Seal** is a single piece Tote Box Security Seal made from polypropylene material. The seal can be supplied plain or with laser marking in various options which include text, serial numbers or barcode.

This seal is used in conjunction with a universal size Tote Box or Attached Lid Containers mainly found in retail, warehousing and distribution securing goods with high value such as jewelry and automation parts.

To remove the seal its simple lift and twist is easily performed and time saving.

Technical Data

Recommended Applications

Plastic Containers, Drums, Tote Boxes, ALC for secure storage and transportation

Material

Polypropylene with Biodegradable additives

Packaging

Standard Packaging : 500 seals/bag
10 bags/carton
Carton Dimensions : 32cm x 29cm x 32cm
Carton weight : 4.5kg/carton

Availability

Plain
Consecutively numbered as standard
Optional Customer name/logo
Optional Laser Barcoding

Colours

White/Yellow/Matt Red/Matt Blue/Matt Green/Pastel Yellow, Pastel Blue, Pastel Green.
Other colours maybe available on request.

